



Over 20,000 units distributed worldwide



More than the micron

PROFILE-ROLL-SYSTEM Type 350



One basic model for every application

Our profile-roll-system, type 350, is optimized to dress profiles on grinding wheels. The used dressing mandrel is fixed in its clamping device and can be additionally equipped with sealing-air and cooling supply. This allows a dressing process under strong conditions (grinding dirt, high pressure of cooling during process). The drive method is available in U- and Z way by using a belt or in direct way. Our fast-changing-system allows a mandrel change, including its diamond roll, within short time by loosening both clamping shells, thus you are able to remove the complete unit without demounting the belt. By default, a belt-crack-detector is mounted. An additional speed-detector, as well as an acoustic emission sensor can be mounted optionally. This allows you to control your dressing step even better. Those kinds of systems are found mostly on flat- and round grinding machines, but are available for every grinding application. Based on this type 350, every individual customer request can be realized.

Your added value

- Vibrationless dressing
- Better grinding surface
- Higher stiffness due to special compound material
- Best condition for grinding wheel and dressing step
- For every grinding application
- Short set-up and maintenance time
- Optimized through sensor use

Fast-changing-system

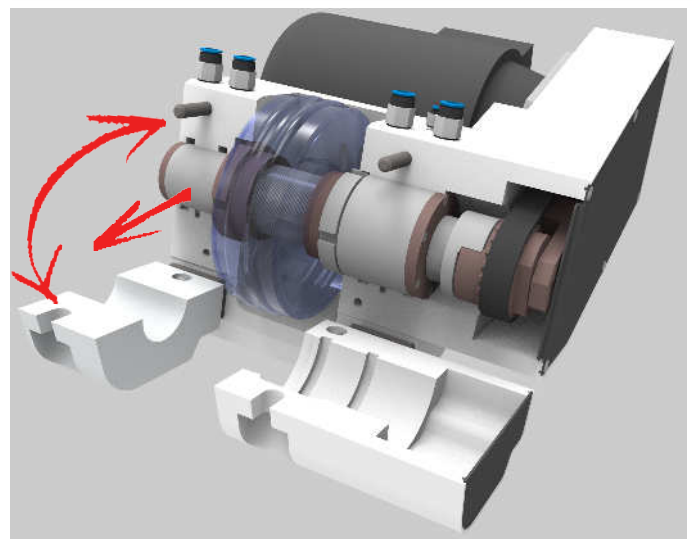

KW Abrichttec GmbH

Behringstrasse 19a
63814 Mainaschaff
GERMANY
Tel.: +49 6021 / 79 00-0
Fax: +49 6021 / 79 00-50
Mail: info@kw-a.de
Web: www.kw-a.de

24/7
Service
Worldwide

